

All Seals

INCORPORATED

The Sealing Specialists

The H-Seal System by Bostec Engineering, is a revolutionary metal seal developed nearly a decade ago for the extreme applications of the Semiconductor industry. During this time the H-Seal has continued to build on its reputation for 100% yields over thousands of applications and excelling in all areas of: sealing, costs, manufacturing yields, and ease of customer usability.

H-Seal

Metal Seal System

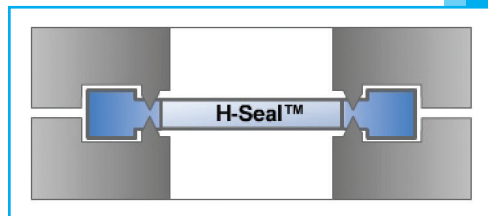

The benefits of the H-Seal over perfluoroelastomers:

- In Ultra High Vacuum (10^{-13}) services.
- It will handle pressures greater than 20,000 PSI.
- The H-Seal is impermeable to moisture.
- Nickel 200 (standard) is virtually inert to most chemicals.
- To temperatures greater than 2,000F.
- The H-Seal will not "out gas" like perfluoroelastomers.
- Eliminates concerns about "explosive decompression".
- Being a metal seal it has virtually unlimited shelf life.

The benefits of the H-Seal over metal o-rings:

- Less compressive force needed to affect a seal; less stress on gland/flanges and bolts.
- Reduction in manufacturing costs, no polishing or extra QC needed.
- 100% manufacturing yields, they seal every time.
- Ease of handling, with the non-critical edges.
- Ease of installation.
- Critical sealing areas are protected.
- No gland damage occurs from using this seal.
- No alignment retainers needed.
- Compression and sealing increase with increased applied force.

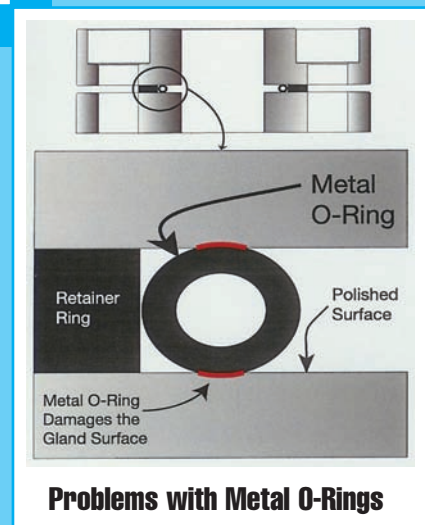

Easy to Handle
All critical sealing surfaces are recessed to prevent damage.

No Gland Polishing Required
No gland polishing is required as minor surface irregularities are absorbed by the H-Seal.

Repeatability
The H-Gland may be used over and over with no loss of performance.

Self-Aligning
No retainer rings needed which simplifies assembly and saves money.

100% Yield
H-Seals work 100% of the time. Guaranteed!

The H-Seal System Components: The Seal and the Gland

The H-Seal:

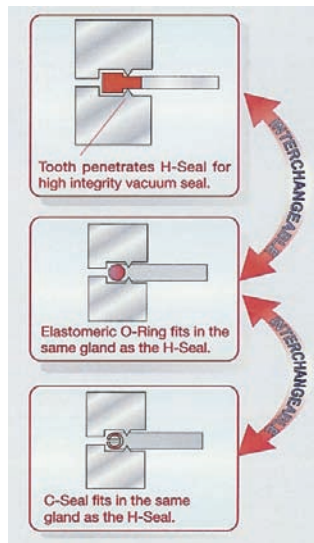

1. Reduced Inventory

O-Rings are directly interchangeable with H-Seals which means a single item of inventory can be used for both elastomeric and metal sealed applications.

2. Increased Manufacturing Efficiency

The H-Seal gland allows you to use elastomeric seals for intermediate or pre-test manufacturing stages, then insert H-Seals for final assembly.

3. Design Conformity

H-Seals conform to standard elastomeric O-Ring dimensions, so there are minimal dimensional adjustments needed with H-Seals.

The H-Seals are more reliable, flexible and cost effective than metal o-rings for numerous reasons. The sealing areas are protected, the seal is self-aligning, the outside diameter is non-critical (allowing for ease of handling), and standard o-rings can still be utilized for testing.

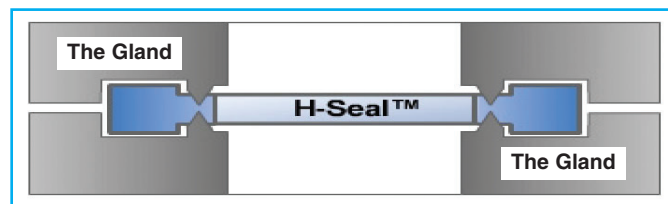

The Gland:

The H-Seal Gland is the other key element. The sixty-degree angle gives us the edge over the competition. You cannot ruin a seal by over-tightening the gland because the top and bottom of the H-Seal act as a stop to prevent over compression. In addition, the gland allows full interchangeability of o-rings, metal o-rings and H-Seals.

Typical Services/Applications for the H-Seal System

1. Ultra High Vacuum Services (UHV) 10⁻¹³
2. High Pressure Services: capable of 20,000+PSI
3. High Temperature Services: capable of 2,000+F
4. Cryogenic Services
5. Automotive: exhaust systems, turbochargers, head gaskets
6. Aerospace
7. Turbines: exhaust systems, high temperatures,
8. Compressors: High pressure sides, LNG, refining,
9. Flow Control: Flow Meters valves,
10. Containment Vessels: casks, ampoules
11. Plastics: high pressures, high temperatures
12. Semiconductor: CVD,PECVD,METAL CVD,HDPCVD, SACVD, ECP
13. Pharmaceutical: UHP, aggressive chemical services.
14. Pipelines: High pressures
15. Scientific Labs: UHV systems, aggressive chemicals
16. Nuclear: Radiation, high pressures, superheated steam, casks
17. Maintenance Repair and Operations (MRO)

Specifications

Materials	Pressures	Temperatures
Nickel 200/201 Copper (Oxy Free) Aluminum Monel Silver Gold	20,000+ PSI	-270F to 2,000+F

ALL SEALS INCORPORATED

404 West Rowland Avenue
Santa Ana, California 92707

Phone: (714) 556-4931

Toll Free: (800) 553-5054

Fax: (714) 557-3257

www.allsealsinc.com